

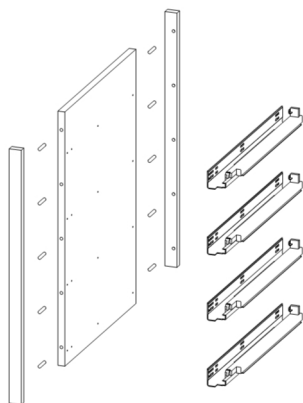

DIVIDER ASSEMBLY



1. ASSEMBLE LEFT AND RIGHT DIVIDER ASSEMBLY USING THE DOWELS PROVIDED. EACH ASSEMBLY CONTAINS 2 CLEATS AND 1 PANEL PRE-DRILLED FOR TANDEM SLIDES.
 2. INSTALL TANDEM SLIDES USING WOOD SCREWS PROVIDED. ALL 5 SCREWS MUST BE USED TO MEET MAXIMUM LOAD CAPACITIES.
- ***NOTE: THE REAR MOUNTING BRACKETS ARE NOT REQUIRED.

GLUE APPLICATION

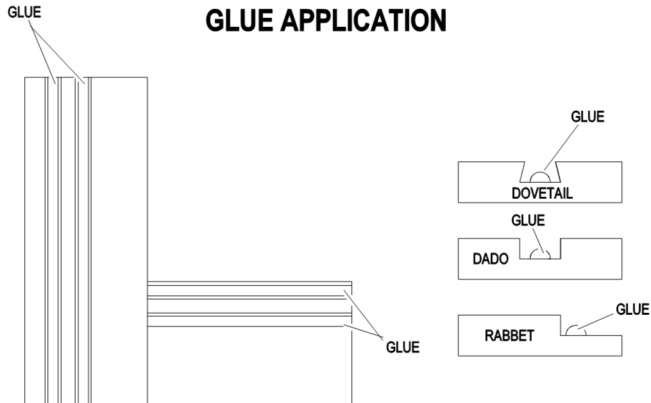

3. APPLY GLUE TO FRONT FRAME AS SHOWN IN GLUE APPLICATION FRAME.

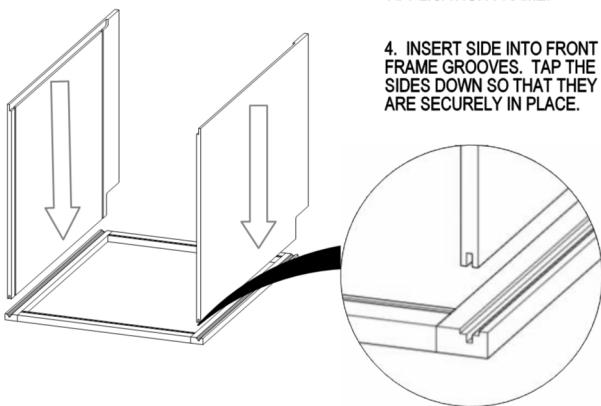

4. INSERT SIDE INTO FRONT FRAME GROOVES. TAP THE SIDES DOWN SO THAT THEY ARE SECURELY IN PLACE.

5. APPLY GLUE TO FEMALE DOVETAIL ON SIDES AS SHOWN IN GLUE APPLICATION FRAME.

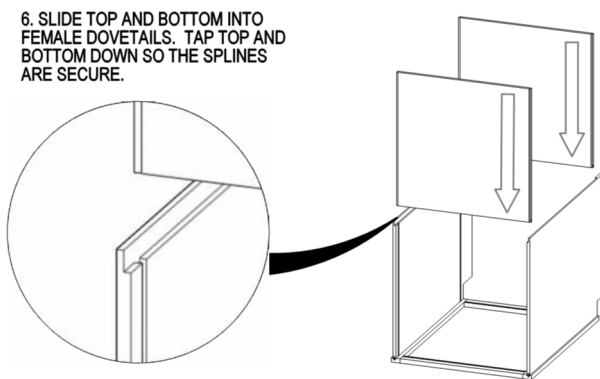

6. SLIDE TOP AND BOTTOM INTO FEMALE DOVETAILS. TAP TOP AND BOTTOM DOWN SO THE SPLINES ARE SECURE.

7. APPLY GLUE TO SIDE RABBET AND DADO AS SHOWN IN GLUE APPLICATION FRAME.

8. INSERT BACK BETWEEN RABBETS IN THE SIDES MAKING SURE THE TOP AND BOTTOM ARE CAPTURED IN THE BACK DADO.

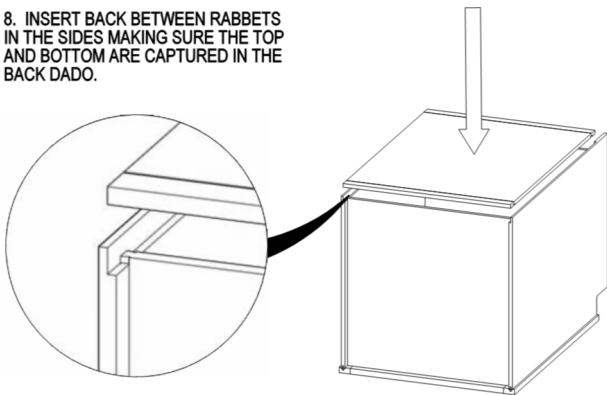

9. PIN OR STAPLE BACK TO TOP AND BOTTOM USING SCRIBE LINE TO LOCATE FASTENERS. PIN OR STAPLES SHOULD BE SPACED A MINIMUM OF 3" APART.

10. PIN OR STAPLE SIDES TO BACK.

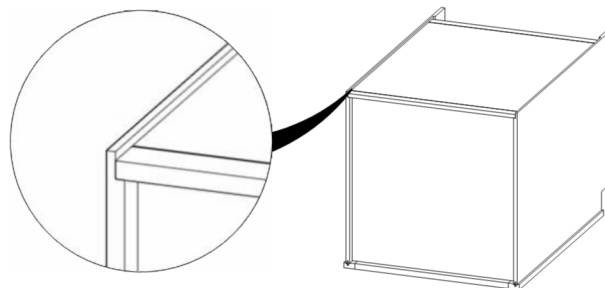

11. INSTALL DIVIDER ASSEMBLIES BY SCREWING THEM TO THE CABINET SIDES. (SCREWS NOT PROVIDED)

